



LUSAS

Overview of LUSAS Geotechnical Capabilities

Overview of LUSAS Geotechnical Capabilities

LUSAS Version 21.0 : Issue 1

LUSAS
Forge House, 66 High Street, Kingston upon Thames,
Surrey, KT1 1HN, United Kingdom

Tel: +44 (0)20 8541 1999

Fax +44 (0)20 8549 9399

Email: info@lusas.com

<http://www.lusas.com>

Distributors Worldwide

Copyright ©1982-2023 LUSAS

All Rights Reserved.

Table of Contents

1 Introduction	3
1.1 Geotechnical capabilities	3
2 Description of facilities.....	5
2.1 Solution process	5
2.2 Activation and deactivation of elements	5
2.3 Displacement reset.....	8
2.4 Spatial variations	8
2.5 Starting condition – Steady state solution.....	12
2.6 K_0 initialisation	12
2.7 Relaxation of K_0 conditions.....	16
2.8 K_0 conditions applied over a stage.....	16
2.9 K_0 initialisation of soil layer	17
2.10 K_0 initialisation and flexible retaining structures.....	18
2.11 Modelling of partially saturated soil.....	18
2.12 Negative porewater pressures: saturated and partially saturated soil .	20
2.13 Phreatic surfaces.....	20
2.14 Arbitrary groundwater distribution.....	22
2.15 Boundary conditions	23
2.16 Automatic time stepping	26
2.17 Calculation of the bulk modulus of water	27
2.18 Excess porewater pressures	28
2.19 Drained and undrained conditions and consolidation analysis	28
2.20 Maximum suction and cavitation pressures	29
2.21 Additional controls for the solution of two-phase solution	30
2.22 Interface elements.....	31
2.23 Phi-C stability analysis.....	33
2.24 Material models	34
3 Modelling examples	37
3.1 Downloads available.....	37

1 Introduction

LUSAS contains many facilities for the analysis and design of civil engineering structures. This manual summarises those facilities applicable to the solution of geotechnical problems, providing details helpful in understanding the options available and how to apply them.

Full details of the modelling facilities available are provided in the LUSAS Modeller online help system. More information on supported material models and general theory is provided in the LUSAS Solver and LUSAS Theory manuals respectively.

1.1 Geotechnical capabilities

Modelling of embankment construction and excavations takes advantage of the element activation and deactivation facility and coupled with the ability to selectively reset displacements of lines and surfaces, as well as elements themselves, ensures that the model geometry closely follows that of the construction sequence. For instance, when applied to the construction of dams, the combination permits a solution which correctly reproduces the design height as well as the correct weight and volume.

Spatial variations are used to describe the variation of material properties such as Young's modulus both through the depth and across the problem domain.

Initial and residual ground stresses can be input directly using the variations available within Modeller. Alternatively, gravity can be applied gradually with a temporary, modified Poisson's ratio to increase the ratio of horizontal to vertical stresses during the initialisation stage. The K_0 facility offers yet another approach which has been extended to help initialise stresses in situations which do not fulfil strict K_0 conditions.

Groundwater flows, static groundwater and consolidation problems including partially saturated flows are handled by the two-phase fluid formulation. Phreatic surface elements are used to define the position of the free water surface making it easy to define the change in water level in a reservoir during drawdown or filling. Additionally, an arbitrary groundwater distribution can be defined using the spatial variations mentioned earlier. An automatic time step size facility provides both an accuracy control and dynamic variation of step size according to the rate of change of porewater pressure or saturation.

Slope stability problems are analysed using phi-c reduction in conjunction with either the Mohr-Coulomb or Hoek-Brown material models. Drained and undrained conditions can be applied to different zones of the soil.

Overview of LUSAS Geotechnical Capabilities

Specialist penalty based interface elements calculate their normal and shear stiffnesses taking account of the surrounding materials. The stiffnesses can be updated as the soil becomes stiffer under increasing load or conversely less stiff as load is removed.

Note

In the following descriptions the convention that tensile stress is positive is adopted, as opposed to geotechnical convention. This is for consistency with the rest of the LUSAS package. All stresses are effective unless otherwise stated.

2 Description of facilities

2.1 Solution process

Geotechnical problems are handled in the nonlinear solution flow of Modeller. A problem is divided into a series of natural stages, such as the excavation of X metres of soil or lowering the water level by an amount Y. A stage can consist of a single action, such as applying a load of X in a single go, or it may be broken down into a series of steps, applying a load of X in 10 steps or increments say. The advantage of applying the load gradually is that this helps convergence with the possibility of increasing or decreasing the rate of loading depending on progress measured by the rate of convergence.

Two possibilities exist for the variation of load. The first is automatic loading, which is independent of time, and uses a scaling parameter λ which runs from a start to a finish value over the stage. All loads defined in the stage are scaled by λ . At the end of the stage a further 'lock-in' stage is required to lock-in the loads to-date before starting on the next stage with new loads to be scaled by λ . The second approach is to use time to describe the variation of load in the form of a load curve. This explicitly defines the load at a given time over the full duration of the problem. Again, the timestep can be adjusted according to solution progress.

2.2 Activation and deactivation of elements

Elements can be activated or deactivated during the analysis to model construction of embankments or excavation of soil for example. By default, all elements are active at the start of the analysis so elements which are to appear later must be deactivated first. Deactivated elements are present in the analysis but with a greatly reduced stiffness and without load. Inactive nodes belonging to inactive elements, if they are not supported, are free to move. This may be desirable, for example in the cantilever construction of a bridge deck, or undesirable, for example in the construction of an embankment as shown in Figure 2.2.1. The option to maintain the original position of the elements can be chosen when deactivating elements.

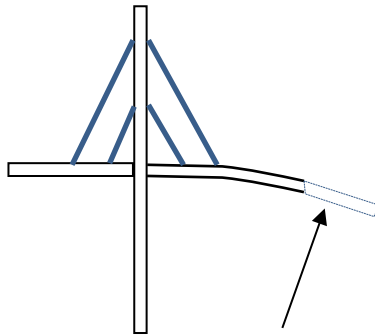

Inactive elements move tangential to existing elements

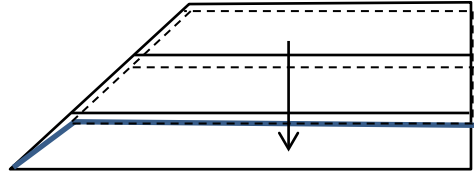

Inactive elements move down

Figure 2.2.1 Movement of inactive elements during solution

Active elements will normally be stressed. This stress is transferred to the adjacent elements via internal nodal forces at shared nodes. On deactivation, the internal forces can be removed in a single increment or gradually over the stage helping convergence when internal forces are large.

It is also possible to reduce the internal forces by a given proportion and then later to reduce them further. This is useful in the construction of a tunnel lining when the remaining soil has not fully relaxed following the excavation but before the lining is installed as shown in Figure 2.2.2.

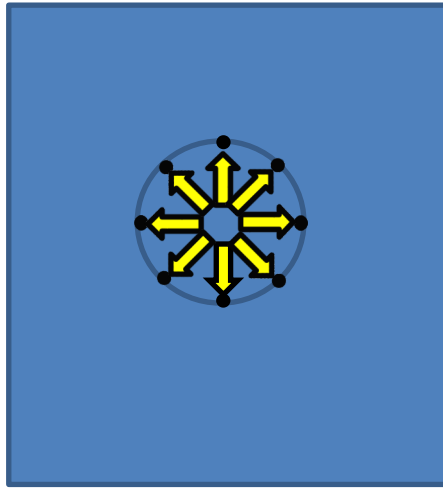

Elements to be deactivated apply forces to adjacent elements

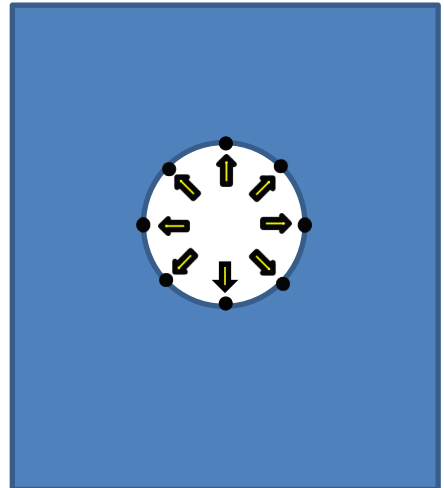

On deactivation the internal forces are reduced by 50%

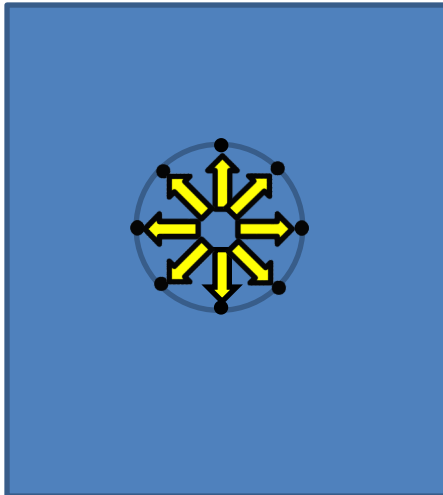

Install tunnel lining

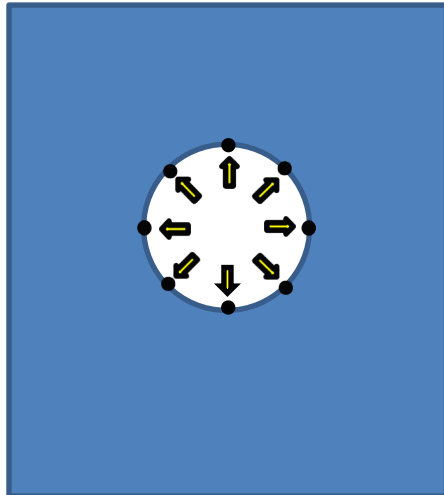

Remove remaining internal forces

Figure 2.2.2 Deactivation of soil during the installation of a tunnel lining

2.3 Displacement reset

A displacement reset is used to restore some or all of the model back to its original position. It can be used at any point in the analysis but is strictly valid only for a model with linear geometry. A displacement reset can be used after establishing the initial ground conditions to restore the starting geometry. During the construction of embankments, it can be used to restore the level of a new layer after it has been initialised but before the next layer is laid on top. The displacement reset is applied to the light blue zones shown in Figure 2.3.1.

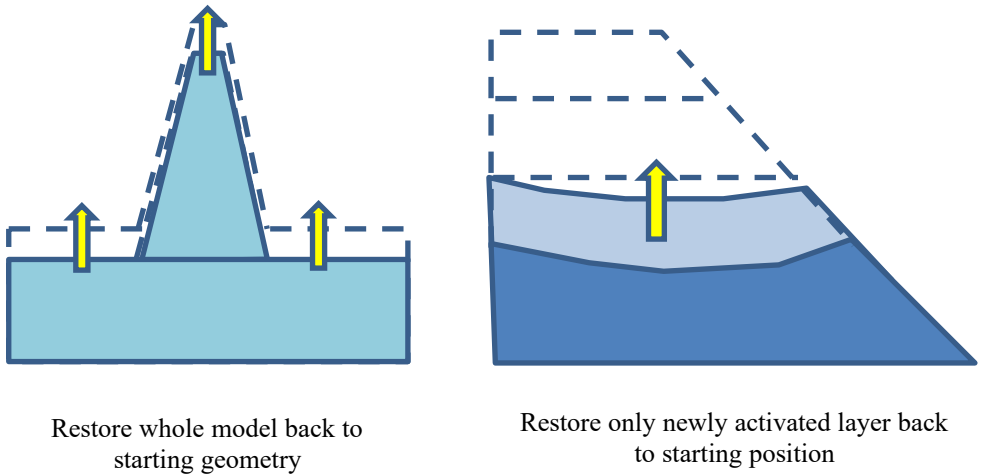

Figure 2.3.1 Displacement resets can be applied to all or part of the model

2.4 Spatial variations

Arbitrary spatial variations of material properties, such as Young's modulus, can be described using the PROFILE facility. The profile can be discontinuous at the boundary between layers as shown in Figure 2.4.1 .

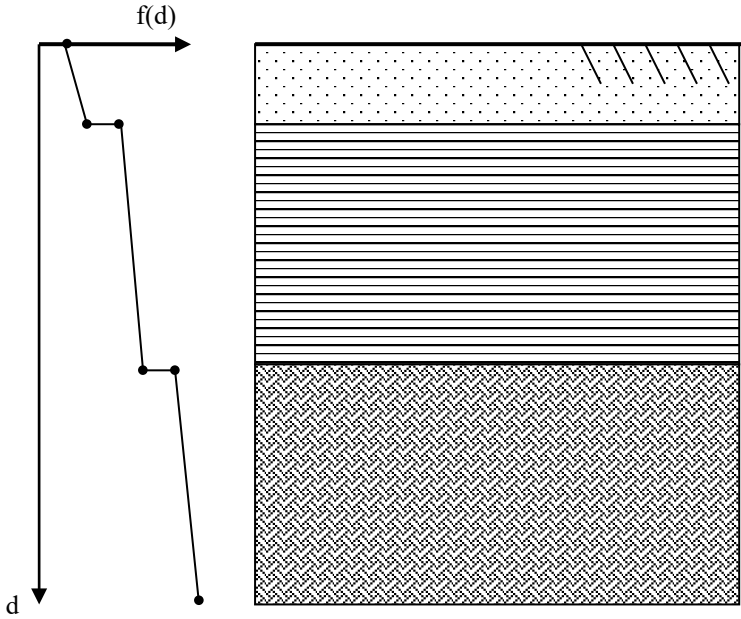

Figure 2.4.1 Single PROFILE defining variation through depth

Individual profiles can be defined at various points in the domain and the material property interpolated at intermediate points. For 2D, the interpolation between profiles is shown in Figure 2.4.2.

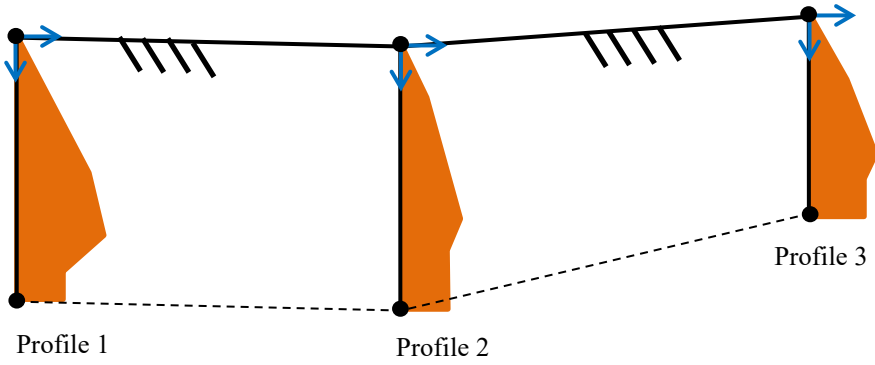

Figure 2.4.2 Interpolation between profiles – 2D

And for 3D in Figure 2.4.3.

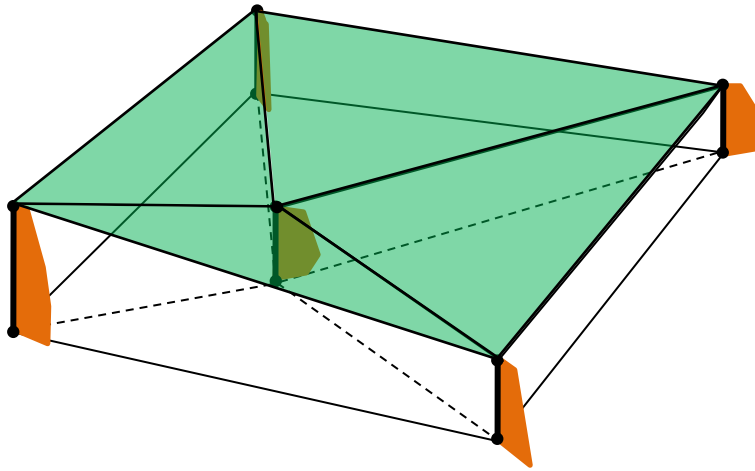

Figure 2.4.3 Interpolation between profiles – 3D

A common use of profiles is to describe the variation of the over-consolidation ratio, OCR, with depth below the surface. At the surface, the OCR changes very rapidly and can go to infinity. When inputting the profile it is important to take into account the quadratic interpolation performed by the element from its nodal values. If the range of OCR values is too extreme a negative OCR can result.

In Figure 2.4.4 a quadratic function is fitted to three points at $x=0, 1$ and 2 . Note, the figure has been turned on its side to help with the visualisation of the change in OCR with depth.

At $x=0$ the function $f(x)=0$, and at $x=1$ $f(x)=1$. At $x=2$ $f(x)$ takes the values $4, 6$ and 10 in turn. The turning point, TP, at which $df/dx=0$ is also listed. For values greater than $f(x)=4$, the function goes negative with the TP lying between 0 and 1 .

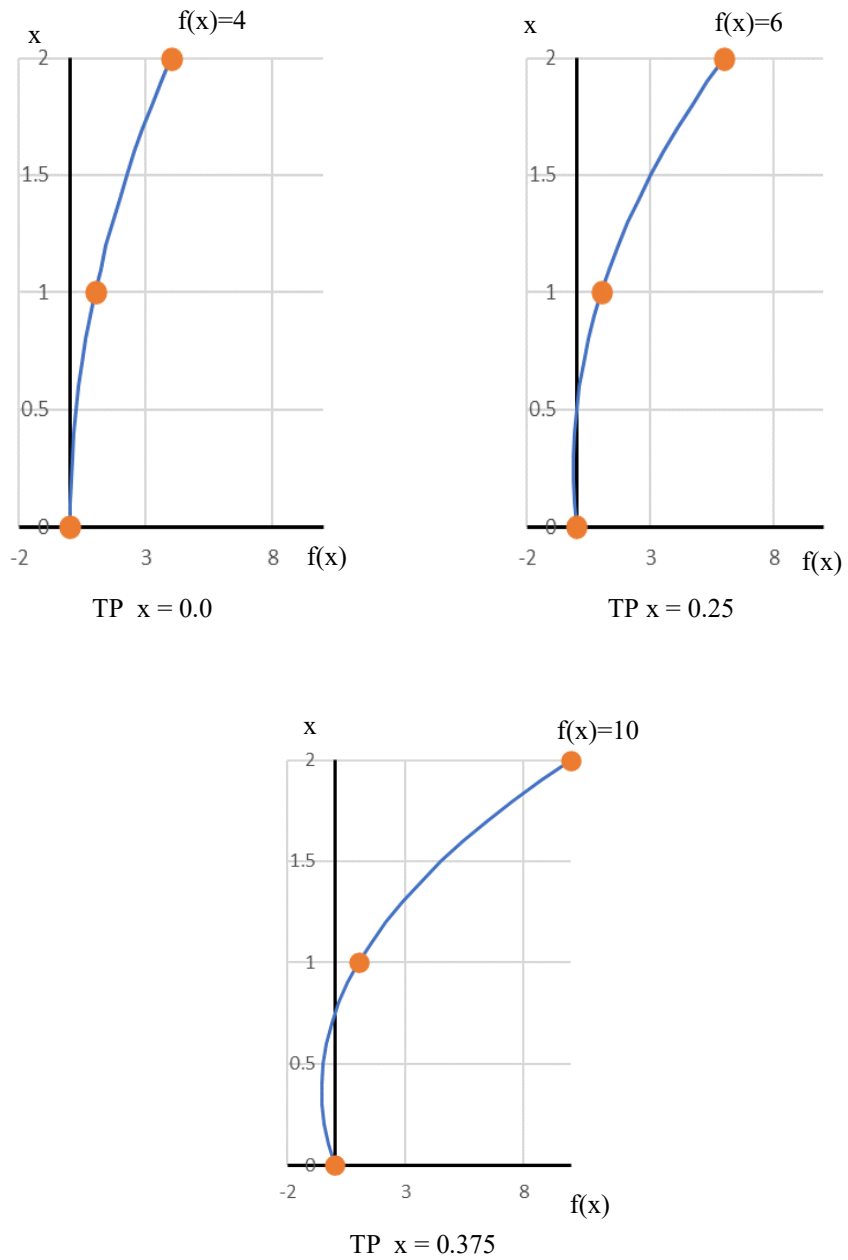

Figure 2.4.4 Variation of Over Consolidation ratio

It is useful to be aware of the behaviour of the element interpolation for other values, although admittedly interpolating an OCR profile is the most likely to lead to problems.

2.5 Starting condition – Steady state solution

A steady state solution is required at the beginning of any geotechnical analysis to establish ground conditions, both of porewater pressures and also the state of stress of the soil. The porewater pressures are calculated first for steady state, fully drained conditions and then soil stresses are evaluated using K_0 conditions or from the application of gravity or the input of a user defined stress distribution. Ordinary isoparametric continuum elements should be used if porewater pressures are not considered.

2.6 K_0 initialisation

In the following *strict* K_0 conditions apply. By this we mean that all soil layers and the phreatic surface are horizontal so that the principal stresses align with the coordinate axes.

In an oedometer test, the soil is loaded vertically but restrained horizontally. Under loading, the ratio, K_0 , of the horizontal stress, σ_H , to the vertical stress, σ_V , is constant.

$$\sigma_H = K_0 \sigma_V \quad 2.6.1$$

As the soil hardens under loading, it undergoes both elastic and plastic straining which is encapsulated by the K_0 value. On unloading, only the elastic strains are recovered with horizontal constraint preventing full recovery of the horizontal stresses. The unloading path is different to the loading path as shown Figure 2.6.1.

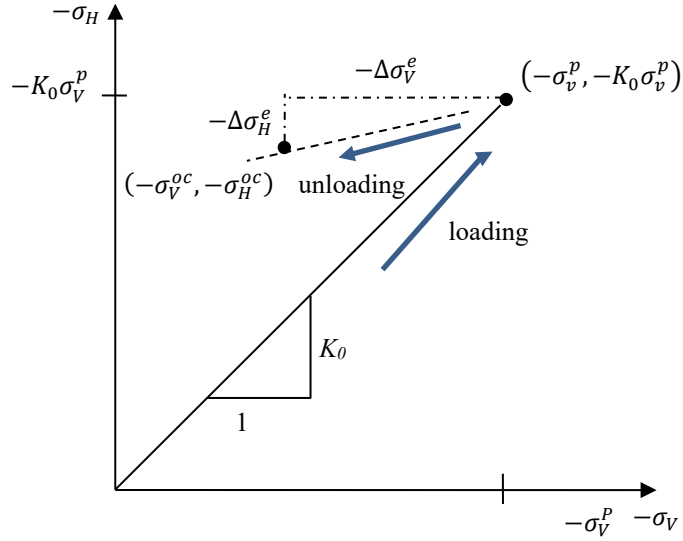

Figure 2.6.1 Stress load path for loading and unloading in oedometer test

The ratio of the current vertical stress $-\sigma_V^{oc}$ to peak vertical stress $-\sigma_V^p$ is known as the over-consolidation ratio, OCR.

$$OCR = \frac{\sigma_V^p}{\sigma_V^{oc}} \quad 2.6.2$$

The peak stresses, $-\sigma_V^p$ and $-K_0\sigma_V^p$, are used to initialise material state variables such as the pre-consolidation pressure of the Modified Cam-clay model. The assumption that the soil unloads elastically whilst fully restrained in the horizontal direction gives the following relationship between the horizontal and vertical elastic stress increments, $\Delta\sigma_H^e$ and $\Delta\sigma_V^e$, and Poisson's ratio ν

$$\frac{\Delta\sigma_H^e}{\Delta\sigma_V^e} = \frac{\nu}{1 - \nu} \quad 2.6.3$$

Expressing this ratio in terms of the stress difference between the peak stress and the unloaded state

$$\frac{\Delta\sigma_H^e}{\Delta\sigma_V^e} = \frac{-\sigma_H^{oc} - (-K_0\sigma_V^p)}{-\sigma_V^{oc} - (-\sigma_V^p)} \quad 2.6.4$$

making use of (2.6.2) and (2.6.3) gives

$$\frac{K_0^{nc} OCR \sigma_V^{oc} - \sigma_H^{oc}}{(OCR - 1) \sigma_V^{oc}} = \frac{\nu}{1 - \nu} \quad 2.6.5$$

and after re-arranging

$$\sigma_H^{oc} = \left[K_0^{nc} OCR - \frac{\nu}{1 - \nu} (OCR - 1) \right] \sigma_V^{oc} \quad 2.6.6$$

The equation relates the current horizontal stress to the current vertical stress following unloading from an historic high. K_0^{nc} is the K_0 value for normally consolidated soil. The K_0 value for the over-consolidated soil, K_0^{oc} , from 2.6.6 is

$$K_0^{oc} = K_0^{nc} OCR - \frac{\nu}{1 - \nu} (OCR - 1) \quad 2.6.7$$

So given an OCR value for the soil and a K_0^{nc} value for normal consolidation we can calculate the horizontal stresses as well as the peak stresses from the vertical stresses as shown in Figure 2.6.2.

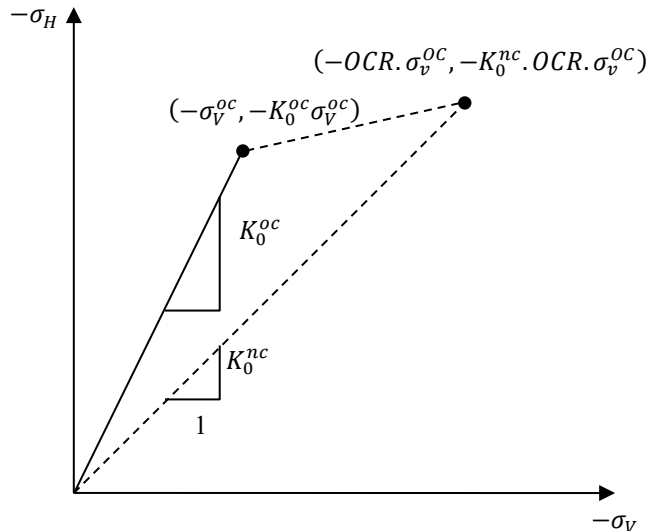

Figure 2.6.2 Calculation of peak stresses from OCR and K_0^{nc}

In Solver the vertical stresses are calculated by assuming the soil is elastic and a Poisson's ratio calculated from

$$\nu = \frac{K_0^{oc}}{1 + K_0^{oc}} \quad 2.6.8$$

On solving, the gravity loading of the soil gives the correct vertical stresses from which the horizontal stresses follow. The OCR is used to calculate the peak stresses which in

turn are used to initialise material state variables. Obviously, we are limited to over-consolidation K_0^{oc} values less than 1.0. Actually, the limit is taken at about $K_0^{oc} \approx 0.9$ to avoid ill conditioning in the solution. However, as the vertical stresses are calculated correctly, satisfying vertical equilibrium, the horizontal stresses are adjusted using

$$\sigma_H^{oc} = K_0^{oc} \sigma_V^{oc} \quad 2.6.9$$

Using the PROFILE facility, the variation of OCR through the depth of the soil can be defined. Solving with the linear elastic representation of the soil the correct horizontal stresses and peak stresses are calculated as shown in Figure 2.6.2..

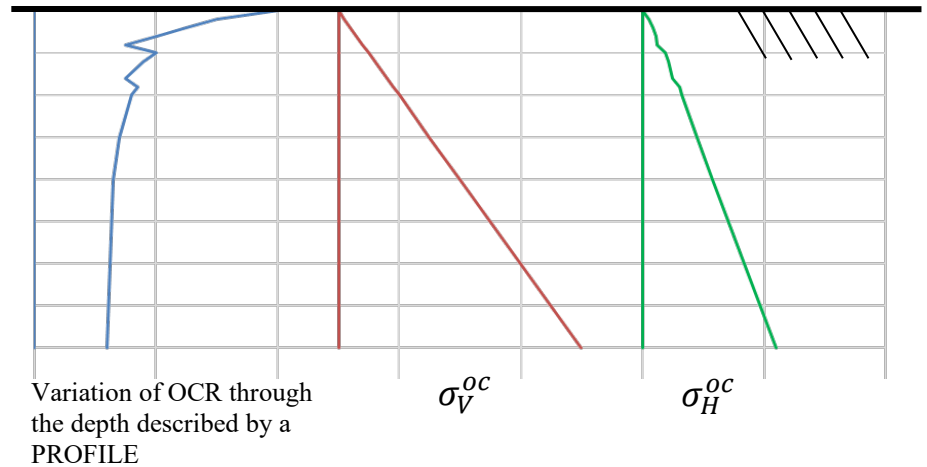

Figure 2.6.2 Use of PROFILE to describe change of OCR with depth

Another way of expressing the historic loading of over-consolidated soil is by defining a pre-overburden pressure, POP. This is a pressure which was applied to the soil but subsequently removed. Following a similar process to above the over-consolidated K_0^{oc} is

$$K_0^{oc} = \left(1 + \frac{POP}{\sigma_V^{oc}} \right) K_0^{nc} - \frac{\nu}{1 - \nu} \frac{POP}{\sigma_V^{oc}} \quad 2.6.10$$

In this case it is not possible to calculate a Poisson's ratio as K_0^{oc} depends on the current vertical stress. The Poisson's ratio corresponding to K_0^{nc} is applied for use in the elastic solution and once the vertical stresses are known the horizontal stresses are corrected using 2.6.9. Close to the surface the vertical stress is small, going to zero at the surface itself, leading 2.6.10 to go to infinity. In practice the stresses are evaluated at the Gauss point which is close to surface but at which the vertical stress is non-zero.

Once the stresses in the soil are calculated from the elastic solution, these stresses are applied as initial stresses to the soil and the problem resolved. If strict K_0 conditions are

met the soil does not displace with the initial stresses being exactly in equilibrium with the soil weight.

It is assumed that during unloading that the stresses remain elastic. However, close the surface differences in stresses may be such as to violate the Mohr-Coulomb yield criterion. If this is the case further iterations are required to return to the yield surface. For the Modified Cam-Clay the stress difference is usually not sufficient to cause the soil to yield.

2.7 Relaxation of K_0 conditions

Unfortunately, strict K_0 conditions only apply in idealized problems. In situations such as the construction of embankments or dams K_0 conditions are most likely to be found in the centre of the structure with the horizontal forces reducing to zero at the edge. However, the use of an initial elastic calculation to obtain some sort of value for the soil stresses is particularly attractive for soil models such as the Modified Cam-clay or the Duncan-Chang whose soil stiffness depends on the state of compressive stress. Again, we can treat the soil as an elastic material and solve for stresses which are used to initialise the soil models' material state variables and provide initial stresses for subsequent iterations. If the initial stresses do not cause any yielding the soil will not displace, however, if the soil has yielded further iterations are required to bring it back to equilibrium. The expectation of yielding during the soil placement means that we may want to use a higher Poisson's ratio in the elastic solution to increase the ratio of horizontal to vertical stresses and by assigning an appropriate K_0 value it is possible to do so.

After the initialisation of the soil stresses, it is recommended that the element displacements are reset to the original geometry.

In some circumstances the elastic solution may result in the soil being in a tensile state for which the stiffness of pressure dependent models is undefined. In this case the parameter defining the minimum strength of the soil is used to ensure that it has some stiffness and no initial stresses are applied. Further iterations will be needed to adjust the solution relaxing the tensile stresses.

2.8 K_0 conditions applied over a stage

The gravity loading of an embankment may require the loading to be applied gradually in order to achieve convergence. In this case, if the application of the load is controlled by the use of automatic loading or time, then the total stresses can be estimated from the first elastic K_0 solution. Knowing the proportion of the applied load, R , the current stresses σ_c , the final stresses σ_F are then calculated

$$\sigma_F = \frac{\sigma_c}{R} \quad 2.8.1$$

where R runs between 0 at the start of the stage and 1 at the end. The stresses at the end of the stage are used to initialise the material state variables. On subsequent loading over

the stage the soil can be expected to be in the elastic state and the Poisson's ratio calculated from K_0 will result with horizontal stresses which are higher than those produced using the original material's Poisson's ratio.

2.9 K_0 initialisation of soil layer

When soil is placed during the construction of an embankment or as backfill it can be dropped from the back of a lorry and pushed into place. It is not the coherent mass assumed by the finite element model. After compaction, the soil behaves more like the solid expected.

The K_0 initialisation of a new soil layer separates the layer from the underlying layers for the duration of the initialisation stage. The stresses in the soil of the new layer are calculated and then transmitted as loads to the underlying soil. At the end of the stage the full gravity load for the layer has been applied and the new soil is then treated contiguously with the rest of the soil.

A very low value of shear stiffness and angle of friction are used to avoid generating shear forces during the placement of soil against a wall. After termination of the stage, the shear interface stiffness and angle of friction are increased to model the friction between the wall and the soil.

The distribution of forces during initialisation of a layer is shown in Figure 2.9.1.

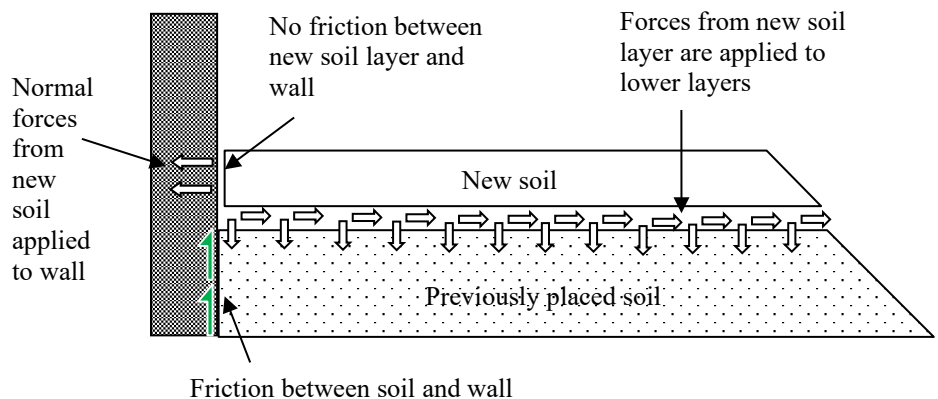

Figure 2.9.1 Forces applied during placement of new soil layer

K_0 initialisation requires that K_0 properties are assigned to the soil. If they are not assigned, the activation of the elements of the new layer will follow the standard behaviour with full connection between new and existing elements.

2.10 K_0 initialisation and flexible retaining structures

The application of K_0 initial stresses from the elastic solution results with zero horizontal and vertical displacement if the K_0 conditions are satisfied exactly. However, when the lateral horizontal stresses are applied to a flexible structure, the structure moves away and the horizontal stresses in the soil relax. To minimise the reduction in stress it is recommended to perform the K_0 initialisation over a load stage with the gradual application of the gravity load. A small initial load leads to small initial stresses. Further loading uses the Poisson's ratio calculated from K_0 leading to the application of higher horizontal stresses until the end of the initialisation.

2.11 Modelling of partially saturated soil

Above the phreatic surface the soil is in a partially saturated state. In the capillary zone capillary forces increase cohesion between soil particles. Above the capillary zone is the two-phase zone and above that the dry zone. As the distance above the phreatic surface increases the suction effect of the capillary forces diminish. This effect is modelled by the soil water characteristic curves (SWCC). LUSAS uses a two-phase model which relates the porewater pressure above the phreatic surface to effective saturation and also relative hydraulic conductivity. Typical distributions through the soil depth are shown in Figure 2.11.1.

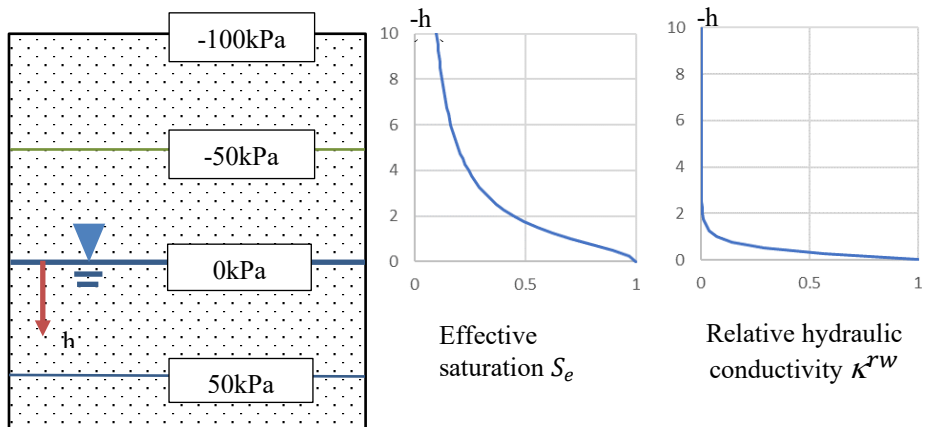

Figure 2.11.1 SWCC plots of saturation and hydraulic conductivity

In the figure 2.11.1 the effective saturation, S_e , drops by half at about 1.75m above the phreatic surface, whilst the relative permeability drops to 10% and is effectively zero at 2m.

There are four options for the input of the soil water characteristic curves.

Van Genuchten-Mualem

$$S_e = \frac{1}{(1 + |\alpha h|^{n_s})^m} \quad \text{and} \quad n_s > 1, \quad m = 1 - \frac{1}{n_s} \quad 2.11.1$$

$$\kappa^{rw} = S_e^{g_l} \left[1 - (1 - S_e^{1/m})^m \right]^2$$

Where α , n_s and g_l are fitting parameters.

Brooks- Corey

$$S_e = \begin{cases} \left(\frac{h_a}{h}\right)^\lambda, & h < h_a \\ 1, & h \geq h_a \end{cases} \quad 2.11.2$$

$$\kappa^{rw} = S_e^{(2+3\lambda)/\lambda}$$

Where h_a and λ are fitting parameters

Valiantzas

A weighted combination of the Van Genuchten/Brooks-Corey models

$$n_G = n_s w^{-0.65 n_s / (0.5 + n_s)}$$

$$S_0 = [1 + (h/h_c)^{n_G}]^{(1-n_s)/n_G}$$

$$S_1 = \left\{ 1 + \left[w \left(S_0^{n_s/(1-n_s)} - 1 \right)^{-1/n_s} + (1-w) S_0^{1/(n_s-1)} \right]^{-n_G} \right\}^{(1-n_s)/n_G} \quad 2.11.3$$

$$S_e = S_0 S_1 \left\{ 1 + \left[w \left(S_1^{n_s/(1-n_s)} - 1 \right)^{-1/n_s} + (1-w) S_1^{1/(n_s-1)} \right]^{-n_G} \right\}^{(n_s-1)/n_G}$$

$$\kappa^{rw} = w S_e^{g_l} \left[1 - (1 - S_e^{1/m})^m \right]^2 + (1-w) S_e^{3+2/(n_s-1)}$$

Where n_s , h_c and g_l are fitting parameters and w is the weighting factor.

Piece-wise linear

The effective saturation and relative hydraulic conductivity are entered in a tabular format at different pressures p_i

Pressure	Relative hydraulic conductivity	Effective saturation
p_i	K_i^{rw}	$S_{e,i}$

Constant saturation

The final and simplest option is to input a constant saturation for the soil above the phreatic surface. If a non-zero value is chosen, then the soil will be subjected to increasing suction as the height above the phreatic surface increases. In this case, a maximum suction should be assigned to the soil limiting the suction contribution to the strength of the soil.

2.12 Negative porewater pressures: saturated and partially saturated soil

For partially saturated soils, the negative porewater pressure above the phreatic surface is correlated to the effective saturation and relative hydraulic conductivity. Negative porewater pressures can also result from the unloading of a fully saturated soil. To avoid misinterpretation of the negative porewater pressure only fully saturated two-phase properties should be used for soil that is fully saturated and in danger of developing negative porewater pressures.

2.13 Phreatic surfaces

Free water levels are modelled using one or more phreatic surface elements. A phreatic surface element marks the position of the free water surface and all points below are at hydrostatic pressure.

Two phreatic surfaces are defined in Figure 2.13.1, one on the upstream side of the wall the other downstream. Pressure is applied as a face load to wall and reservoir bed and additionally, if the elements are two-phase, the porewater pressure at the boundary nodes is also set.

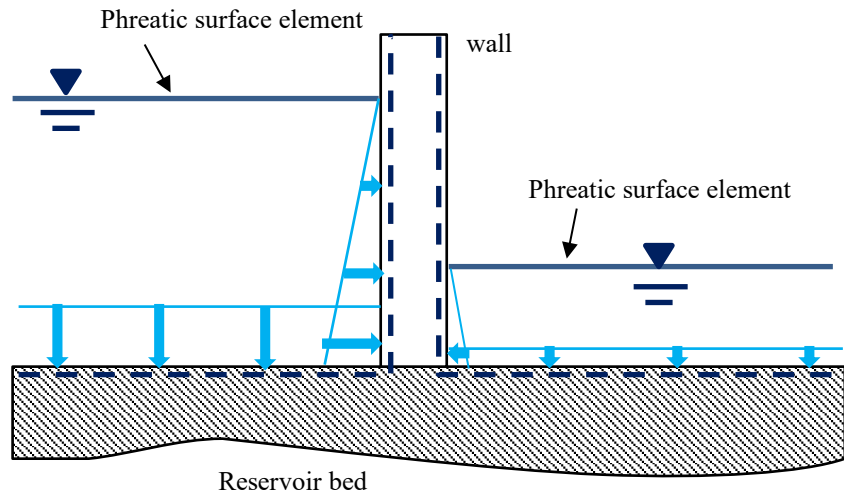

Figure 2.13.1 Use of phreatic surface elements

The water level is raised or lowered by applying a prescribed displacement to the phreatic surface element changing the hydrostatic pressure distribution. The weight of the fluid can be scaled using automatic loading or load curves. This changes the applied pressure but not the hydrostatic pressure distribution.

Phreatic surfaces can also be used to apply underground boundary conditions as shown in Figure 2.13.2.

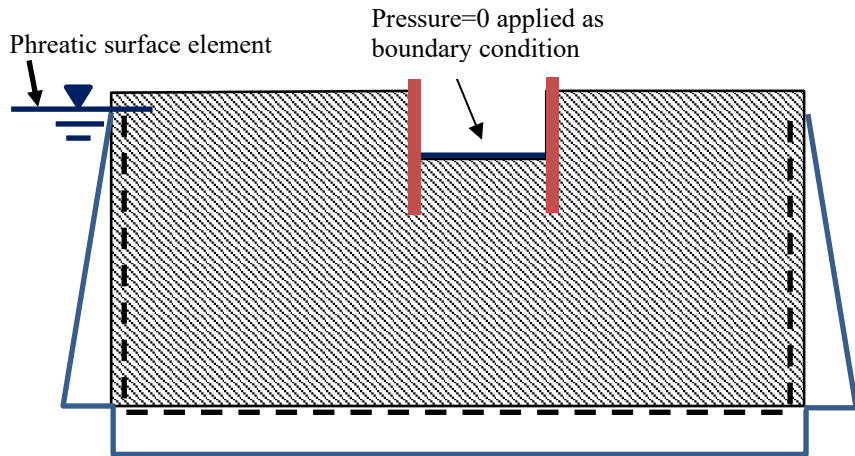

Figure 2.13.2 Application of phreatic surface to domain boundaries

A single phreatic surface element is defined on the lefthand side of the domain. It is associated with the three edges of the ground. It is not necessary for a point to be directly under the phreatic surface, for as long as the surface is defined by a single element, it is unambiguous. If the phreatic surface comprises two or more phreatic surface elements, then the pressure at a point is calculated from the phreatic element directly above the point.

Hydrostatic porewater pressures are fixed along the ground boundaries. Optionally, the hydrostatic pressures can be applied as well. In the first instance, by just setting the porewater pressures, the reactions are calculated from total stresses, whilst if the porewater pressure is applied the reactions are in terms of effective stresses. Inside the excavation, the condition that the pressure is atmospheric is set using a normal boundary condition. A second phreatic surface could also be defined, which is especially convenient if the water level is to be changed.

2.14 Arbitrary groundwater distribution

A background groundwater distribution can be defined using a PROFILE set. Individual profiles are defined through the depth, as shown in Figure 2.14.1, and the porewater pressures between these profiles are linearly interpolated. The porewater pressures cannot be changed during the analysis but excess porewater pressures can be generated from undrained loading. On consolidation, the excess porewater pressures are drained and the underlying groundwater distribution recovered.

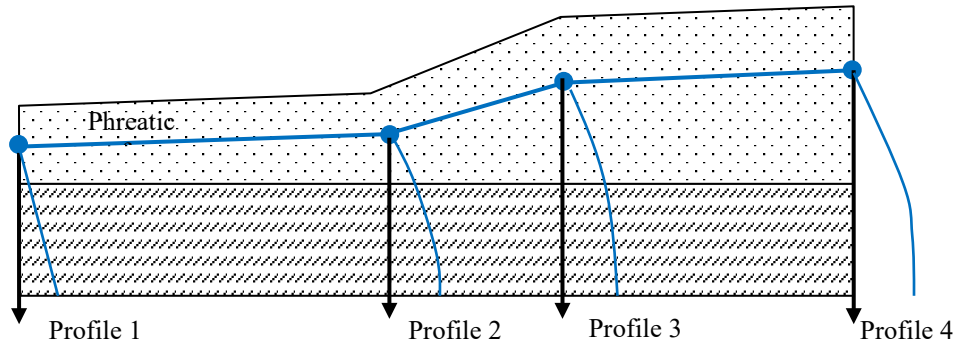

Figure 2.14.1 Profiles defining known groundwater variation

2.15 Boundary conditions

Several types of fluid flow boundary conditions can be applied to individual nodes.

Open

Porewater can flow into and out of the soil at the node. The porewater pressure is fixed.

Closed

Porewater cannot flow into or out of the soil at the node. The porewater pressure is free and can rise or fall. If a previously *closed* node is to be opened, then the required pressure after opening should be set using a total prescribed displacement.

Seepage

Seepage boundary conditions are applied along a ground surface which is intersected by the phreatic surface. Nodes which lie above the phreatic surface are closed whilst those which lie below are open with the porewater pressure set to zero.

In Figure 2.15.1, seepage boundary conditions are set for the portion of the wall above the phreatic surface on the downstream side. They should not be assigned to the boundaries below the water level which get both their boundary conditions and pressure load from the phreatic surface elements.

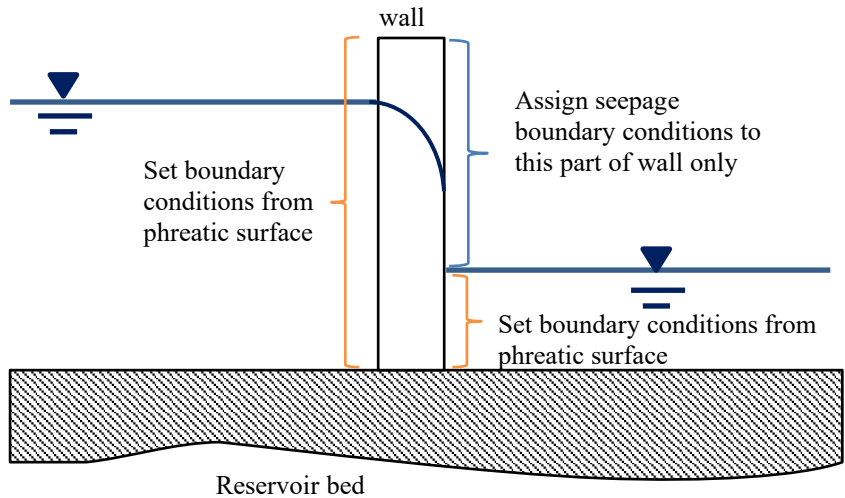

Figure 2.15.1 Use of seepage boundary condition

Seepage boundary conditions are inconvenient for use on a surface for which the water level is changing, especially if automatic step sizing is in action. Phreatic surface boundary conditions should be assigned as shown in Figure 2.15.2.

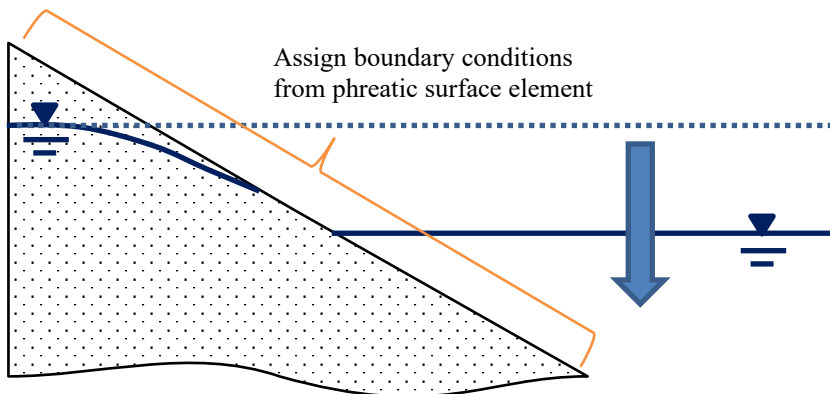

Figure 2.15.2 Flow boundary conditions with moving phreatic

The open or closed status of nodes using seepage boundary conditions is updated on each iteration and seepage boundary conditions should be preferred wherever possible. They are, however, difficult to use on boundaries which are connected to a moving phreatic surface. Instead, a simple one step procedure is adopted when using the phreatic surface elements. On the first iteration of a new step the resulting porewater pressure solution is used to set the status of opened or closed for all nodes on the surface. This status is then fixed for the duration of the increment.

Seepage boundary conditions are also useful for modelling the ingress of water into a partially saturated soil. If the rate of ingression is greater than the ability of the water to disperse, the soil at the surface becomes saturated and unable to accept any more water as shown in Figure 2.15.3. At this point the seepage boundary condition sets the porewater pressure to zero and accepts no more water. No account is taken of water runoff which follows ground saturation.

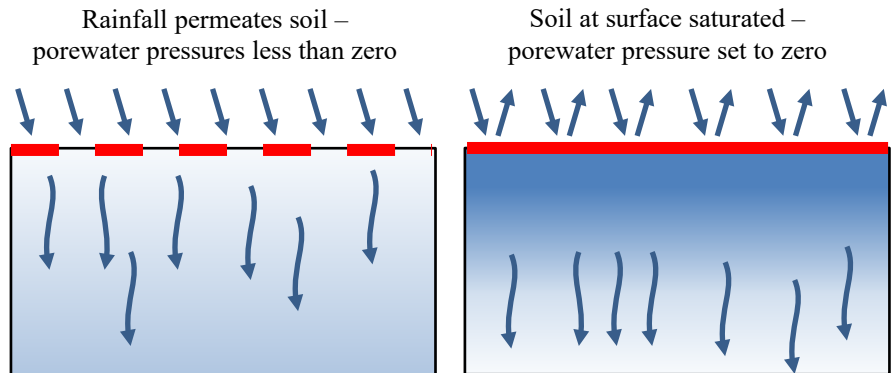

Figure 2.15.3 Seepage boundary conditions and saturated ground

Consolidation

Consolidation boundary conditions are used to restore the steady state porewater pressure at the boundary immediately prior to the undrained loading. It is an alternative to re-applying the porewater pressure boundary conditions and is particularly useful if the condition applies to partially saturated soil.

Viscous / non-reflecting boundaries

In an analysis, the model domain represents a finite region of essentially unbounded rock and soil. For a static analysis the aim is to make the model sufficiently large for the influence of the boundaries to be negligible. In dynamic analyses waves propagate through the soil and are reflected back into the domain at these boundaries. Figure 2.15.4 shows circular waves emanating from a point source and their reflection at the boundaries.

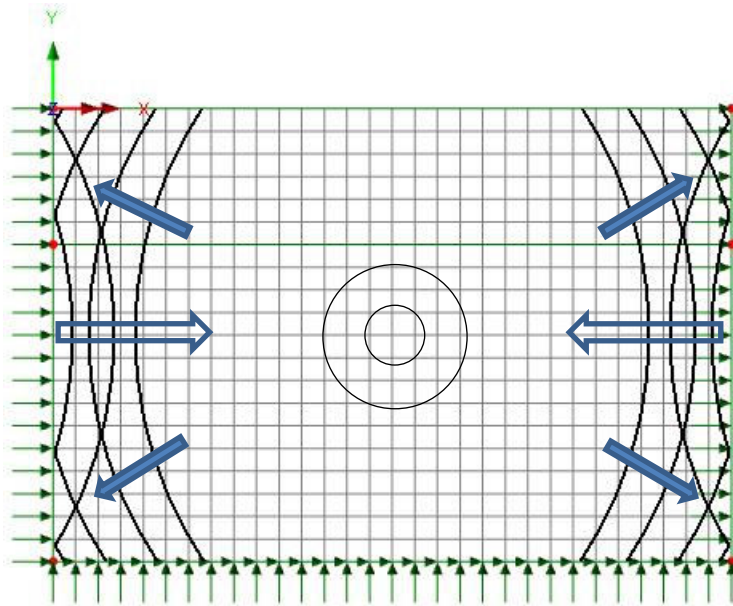

Figure 2.15.4 Reflection of circular waves from point source

In general, it is impractical to make the model sufficiently large for the effects of the reflected waves to be negligible. Viscous boundaries allow the passage of the waves out of the domain minimizing reflections. In the initialisation stage of the geotechnical model the average bulk and shear moduli are extracted at the boundaries and are used to evaluate the damping properties of the viscous supports. Additional relaxation coefficients can be applied if required.

2.16 Automatic time stepping

Consolidation analyses are characterized with a rapid change in porewater pressure at the start of the analysis and much slower changes at the end. Typical behaviour is shown in Figure 2.16.1.

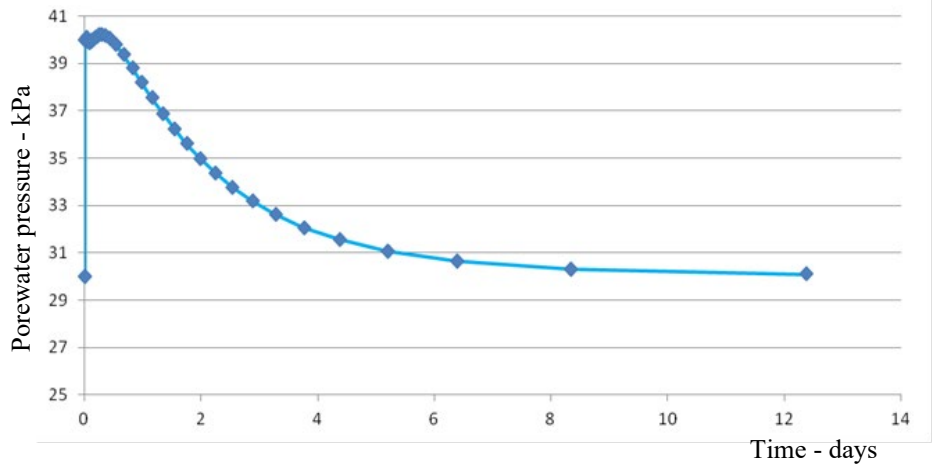

Figure 2.16.1 Typical change of porewater pressure during consolidation

A simple control to calculate an appropriate timestep is to set a target change of pressure over an increment, Δp^{target} . Given that the current timestep, Δt_i , and the maximum change in pressure at any node, Δp_i^{max} , are known at time step i , a new time step, Δt_{i+1} , can be estimated from

$$\Delta t_{i+1} = \Delta t_i \frac{\Delta p^{target}}{\Delta p_i^{max}} \quad 2.16.1$$

Once the pressures have been solved, a check is made to ensure that the actual maximum change in pressure does not exceed the target by more than a factor of two. If it does the solution performs a step-halve and resolves.

A similar control is also applied for a target change in saturation, Δsat^{target} over the time step.

$$\Delta t_{i+1} = \Delta t_i \frac{\Delta sat^{target}}{\Delta sat_i^{max}} \quad 2.16.2$$

The automatic controls on saturation and pressure are applicable to all groundwater flow problems.

2.17 Calculation of the bulk modulus of water

There are three options to input the bulk modulus of water, K_w . It can be input directly, evaluated from the Poisson's ratio of the undrained soil, ν_u , or from the bulk modulus of the soil, K_{soil} . The motivation behind the last two methods is that the water bulk modulus

is very large compared to that of the soil which can lead to ill-conditioning and numerical problems in the solution.

Direct input

The bulk modulus of water is approximately 2200 MPa

Calculated from Poisson's ratio of the undrained soil

A Poisson's ratio for the undrained soil, ν_u , of 0.495 is suggested.

$$K_W = 3 \frac{(\nu_U - \nu)}{(1 - 2\nu_U)(1 + \nu)} K_{soil} n \quad 2.17.1$$

where ν is the Poisson ratio of the soil and n its permeability.

Calculation from the bulk modulus of the soil

The soil bulk modulus is multiplied by the factor α . A value between 10 and 100 is suggested.

$$K_W = \alpha K_{soil} \quad 2.17.2$$

2.18 Excess porewater pressures

Excess porewater pressures are calculated from the last steady state solution. If the porewater pressure boundary conditions change by say lowering a phreatic surface then the steady solution will also change but the excess porewater pressures are not updated to the new conditions. The excess porewater pressures continue to be measured from the original steady state solution and will not return to zero when the steady state for the updated conditions is established at some point in the future.

2.19 Drained and undrained conditions and consolidation analysis

Drained/undrained conditions are used in static analyses only. To model a short-term loading a soil such as clay may be considered to be undrained whilst a sand may be considered to be drained. If the soil is undrained, then the bulk modulus of water is included in the element stiffness calculation, whilst conversely if the soil is drained it is omitted. If undrained elements are present, then the porewater pressures are not allowed to dissipate leading to the generation of excess porewater pressures. The undrained solution can then be followed by a consolidation analysis to disperse the excess porewater pressures. The drained/undrained conditions are not used once the consolidation analysis starts – they are only used in the static part setting up the starting conditions.

Alternatively, a consolidation analysis can be conducted entirely in the time domain, with the loading being applied over a short-time period, followed by consolidation over a longer time period.

2.20 Maximum suction and cavitation pressures

The porewater pressure affects the total stresses of the soil and large changes in porewater pressure can lead to unrealistic stresses. The total stresses, σ , are calculated from

$$\sigma = \sigma' - \alpha_b \mathbf{m} S_w p \quad 2.20.1$$

where σ' is the effective stresses, α_b Biot's constant, \mathbf{m} a vector to add the porewater pressure p , to the direct stresses and S_w the saturation. Remember: stresses are positive in tension. Consider a point at the surface above the phreatic surface, with little or no total stress and a porewater pressure of $-p_{surf}$. Equation 2.20.1 becomes

$$\sigma' = -\alpha_b \mathbf{m} S_w p_{surf} \quad 2.20.2$$

The negative porewater pressure or suction translates into the application of compressive stress to the soil.

When using the full SWCC input the suction effect of the capillary zone is correctly accounted for. In the simplified input of the partially saturated parameters, where just a maximum and minimum water content is specified, as the distance above the phreatic surface increases so does the suction, as shown in Figure 2.20.1. A maximum suction stress should be set to provide a cut-off.

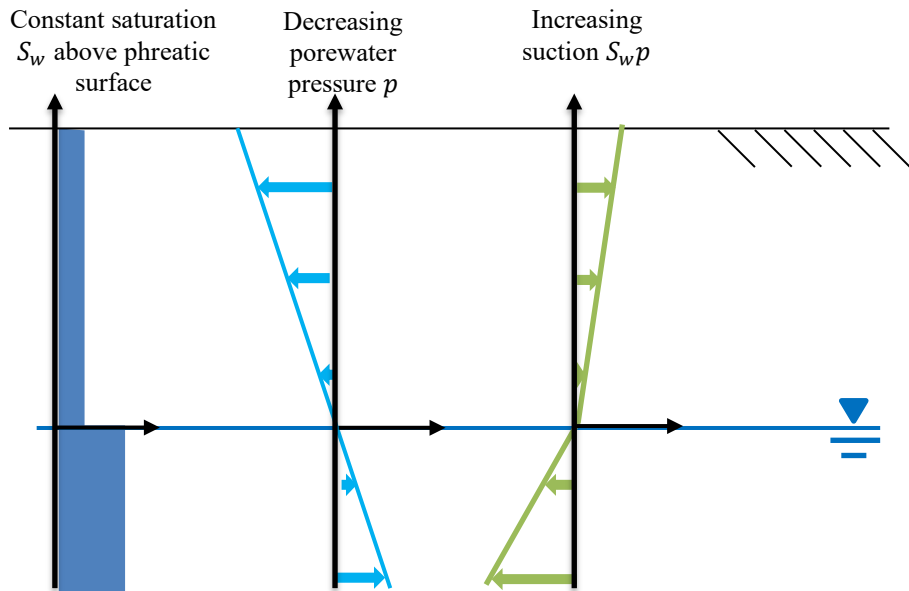

Figure 2.20.1 Unbounded increase in suction

When undrained soil is loaded in compression, the new load is mainly carried by the increase in porewater pressure with the remainder carried by the soil skeleton. On unloading the reverse happens, the soil expands there is large drop in porewater pressure with the drop in pressure increasing the strength of the soil. A cut-off cavitation pressure can be specified to limit the pressure applied to the soil skeleton. It is only used in undrained, static analyses.

2.21 Additional controls for the solution of two-phase solution

In drained analyses, the solution of the porewater pressures is independent of the solution of the displacements. The porewater pressures can be solved for first and then fed into the displacement calculation. If the displacements and the porewater pressures are to be solved together in a linear analysis, the non-symmetric solver must be used. In general flow and consolidation problems the porewater pressures are solved with the displacements but more precise control over the solution is provided by the options

1. Solve pressures first and then solve with displacements
2. Solve pressures first and fix
3. Solve pressures and displacements together

Additionally, it is possible to control the update, or not, of the permeability of partially saturated soil. These controls are in general not needed but provide additional flexibility when convergence is proving difficult.

2.22 Interface elements

Interface elements are usually placed between two disparate material such as soil and concrete. They define a discontinuity in the mesh where two elements can slide against each other. A Mohr-Coulomb friction law is used where the limiting shear stress F_S is proportional to the normal stress F_N

$$F_S = c - F_N \tan \phi \quad 2.22.1$$

where c is the cohesion and ϕ the angle of friction. The relationship is shown in Figure 2.22.1.

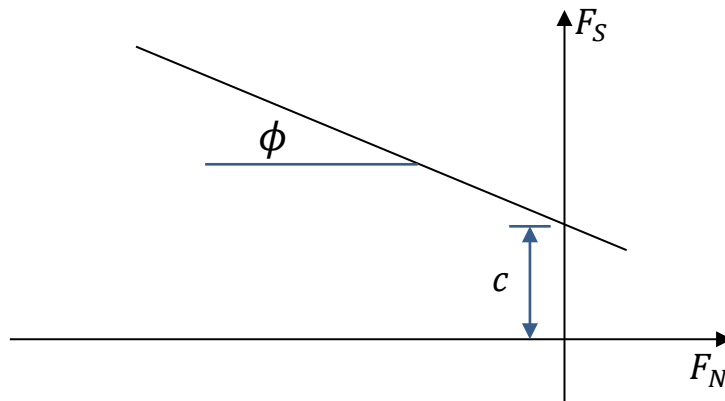

Figure 2.22.1 Mohr-Coulomb Friction

The calculation of the normal and shear stresses uses a penalty approach multiplying the shear stiffness, K_S , and normal stiffness, K_N , by the relative displacements of the two sides of the interface, Δu and Δv , as shown in Figure 2.22.2.

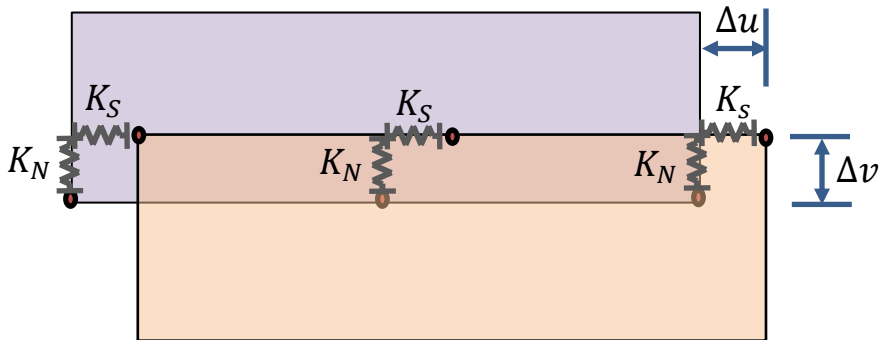

Figure 2.22.2 Shear and normal stiffnesses at interface

The values of K_N and K_S can be input directly or calculated from Young and shear moduli, E_{mat} and G_{mat} , of the materials on either side of the interface. User defined factors α_N and α_S are applied to these values

$$K_N = \alpha_N \max(E_{mat1}, E_{mat2})$$

$$K_S = \alpha_S \min(G_{mat1}, G_{mat2})$$
2.22.2

Typical values are $\alpha_N=10$ for the normal stiffness and $\alpha_S=0.15$ for the shear stiffness.

The stiffness of pressure dependent soils varies with depth so interface stiffnesses vary as well. The values may be optionally updated at the end of each step or even iteration when they change due to loading or excavation.

Interfaces elements also provide a path for, or a barrier to, the flow of water. In the case of a retaining wall, no flow is possible across it if it is modelled using isoparametric continuum elements. If the wall is modelled as a plane strain beam in 2D or a shell element in 3D, flow is only possible if a hydraulic conductivity, K_{gap} , is assigned to both interface elements, one on either side of the wall. See Figure 2.22.3

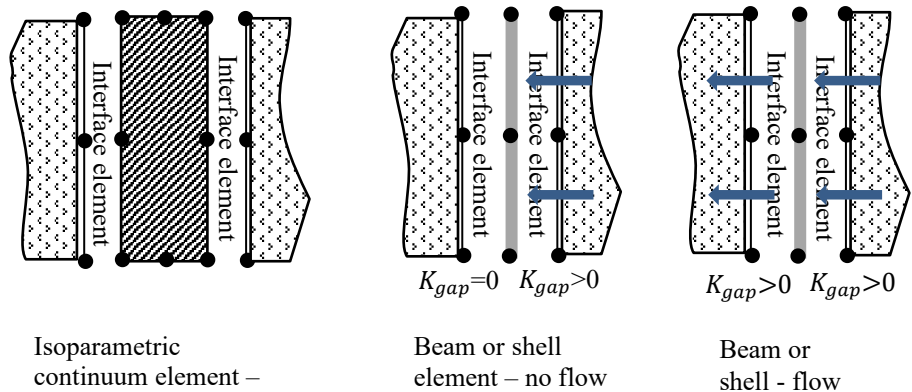

Figure 2.22.3 Interface elements either side of a modelled wall

2.23 Phi-C stability analysis

The phi-c stability analysis can be performed using either the Mohr-Coulomb or Hoek-Brown material models during which the shear resistance of the soil is gradually reduced until the soil fails. As the soil approaches failure, smaller and smaller steps are required to solve for equilibrium with large shear strains and displacements developing in the area of failure.

The safety factor, SF , is defined in terms of the initial value of the shear resistance divided by the shear resistance at failure. For the Mohr-Coulomb model this is expressed by

$$SF = \frac{C - \sigma_n \tan \phi}{C_f - \sigma_n \tan \phi_f} \quad 2.23.1$$

where C and ϕ are the cohesion and angle of friction of the soil respectively and C_f and ϕ_f are the cohesion and angle of friction at failure. For the Hoek-Brown model, the shear stress/normal stress envelop is calculated. The shear stress is then factored and a new Hoek-Brown failure surface calculated which satisfies the reduced shear stress whilst maintaining the normal stress and position of the apex.

The phi-c analysis is run by gradually increasing the safety factor SF . As failure is approached the change in SF between converged increments get smaller and smaller as it becomes more and more difficult to get a converged solution. The analysis terminates once the change in SF between successive solutions falls below a given tolerance – a value between 0.01 and 0.001 is recommended.

Phi-c is a static analysis so drained/undrained conditions apply to the soil and can be set for either the whole model or to specific parts of the model by the user. If the soil is

undrained the bulk modulus of the water is included in the solution and no flow conditions are enforced. If the phi-c analysis is performed following a groundwater flow or consolidation analysis the soil is assumed to be undrained. If a drained solution is required, then drained properties must be assigned to all the elements. The porewater pressures are then frozen during the phi-c reduction. Alternatively, the steady state solution may be calculated first to ensure the correct porewater pressure distribution and then followed by the phi-c reduction.

2.24 Material models

A basic description of supported material models and their uses is provided here. More information and general theory is provided in the LUSAS Solver and LUSAS Theory manuals respectively.

2.24.1 Mohr-Coulomb

Commonly used for the modelling of granular material but also often used for cohesive soils as well. This implementation. Includes strain hardening of cohesion and friction angle.

2.24.2 Modified Mohr-Coulomb

The Mohr-Coulomb model is supplemented by a tension cut-off. A Rankine surface limits the principal tensile stress whilst a pressure cutoff can also be used. If the soil has no cohesion, it is better to set a cohesion of one and then set the tensile cutoff stress to zero. Setting the angle of friction to zero recovers the Tresca yield criterion.

2.24.3 Hoek-Brown

The model is an elastic-perfectly-plastic constitutive model suitable for the modelling of rock failure. It is an empirical model and its parameters are based on both laboratory test data and visual observation of the rock.

2.24.4 Tresca

Used in the undrained analysis of soils.

2.24.5 Drucker-Prager

Used in the analysis of frictional materials such as sand. The Mohr-Coulomb criterion is usually preferred.

2.24.6 Duncan-Chang

Used for the modelling of soils. It has a pressure dependent stiffness. Using an explicit incremental elastic approach, solution accuracy depends on the size of the loading increments.

2.24.7 Modified Cam-clay

Used for modelling of normally consolidated soft soil and clays.

3 Modelling examples

3.1 Downloads available

A number of step-by-step, general overview and verification examples are provided for download from the user area of the LUSAS website.

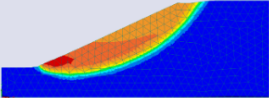
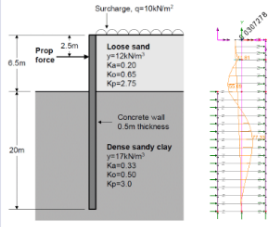
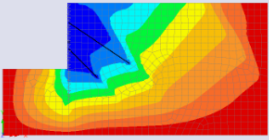
Step-by-step Worked Example	Keywords	Notes
 <p>Slope Stability Modelling</p>	2D, Inplane, Soil, Geotechnical, Phi-C reduction, (Geostatic) step, Nonlinear, Analysis branch, Safety factors, Displacements.	Updated for V21
 <p>Embedded Retaining Wall</p>	2D, Inplane, Retaining wall, Drained, Nonlinear, Excavation, Surface heave, Plane strain, Prop force, Bending Moment.	Updated for V21
 <p>Dry Excavation</p>	2D, Inplane, Geotechnical, Excavation, Staged Construction, Two phase elements, Activation, Deactivation, Interface elements, Water pressure, Displacement, Calculation of bending moment, axial and shear forces from 2D stresses.	New for V21

- **Step-by-step worked examples** provide detailed instructions to create models and view results.
- **Overview examples** provide a general overview of how to model the application shown, and require prior knowledge of modelling with LUSAS.
- **Verification examples** provide a comparison of results with those from published solutions and other software applications.



LUSAS

LUSAS, Forge House, 66 High Street, Kingston upon Thames, Surrey, KT1 1HN, UK
Tel: +44 (0)20 8541 1999 | Fax: +44 (0)20 8549 9399 | info@lusas.com | www.lusas.com